

*BACK VIEW*

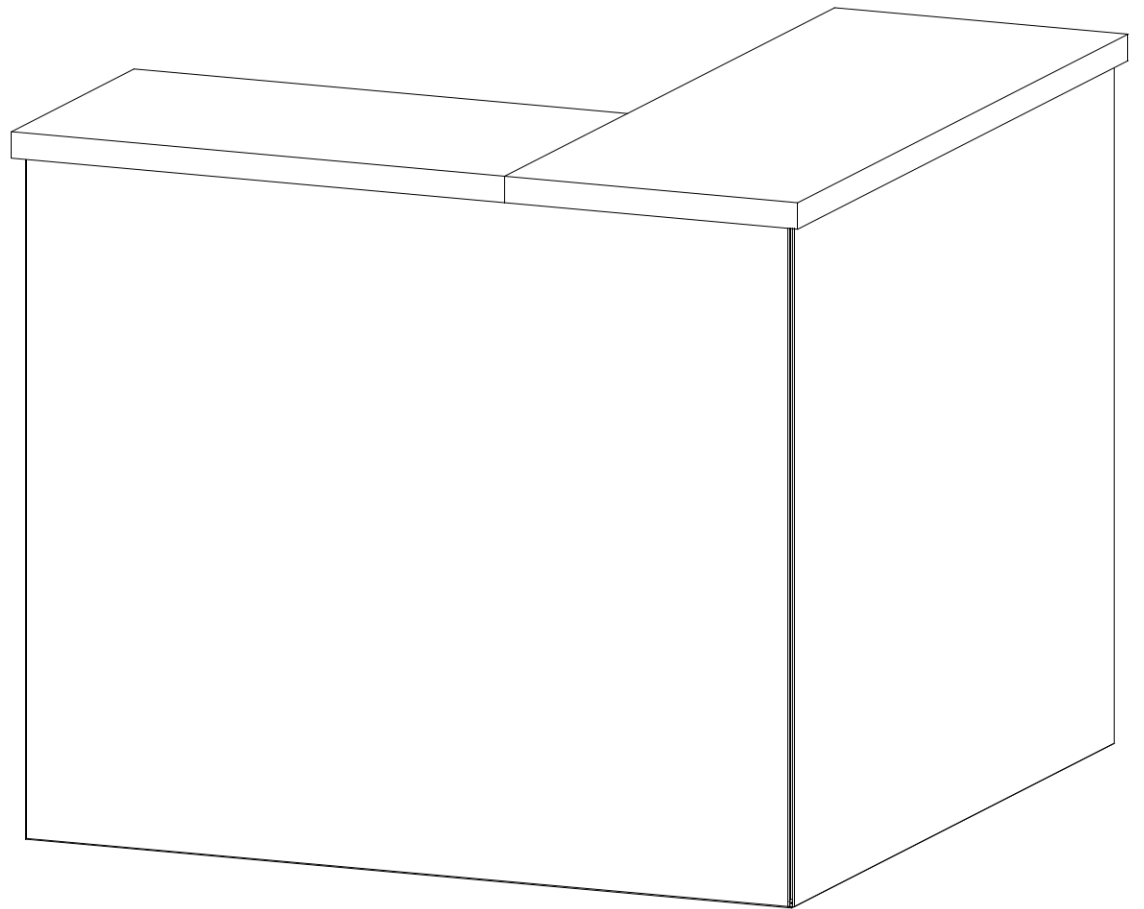

*FRONT VIEW*

## General Setup Instructions

- Read entire setup instruction manual prior to unpacking parts and pieces.
- The setup instructions are created specifically for this configuration.
- Setup instructions are laid out sequentially in steps, including exploded views with detailed explanation for assembly.

## Cleaning & Packing

- For Cleaning Metal, Plex, & Laminate Parts: Use a **MILD NON-ABRASIVE** cleanser and soft cloth/paper towel to clean all surfaces.
- Keep exhibit components away from heat and prolonged sun exposure.  
**Heat and UV exposure will warp and fade components.**
- Retain all provided Packing Materials. All provided packing materials are for ease of repacking & component protection.

## Disassembly

- For loss prevention, tighten all set screws and locks during disassembly.

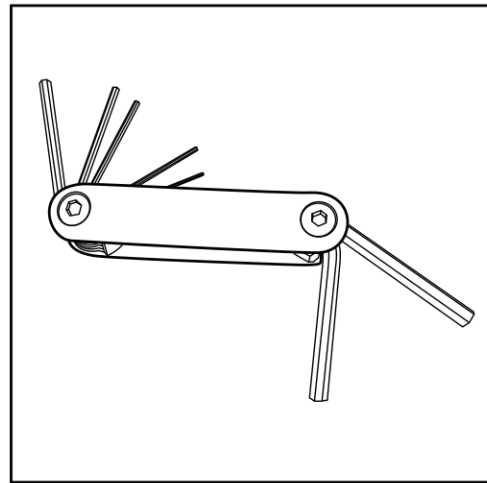

Hex Tool - Essential for Assembly

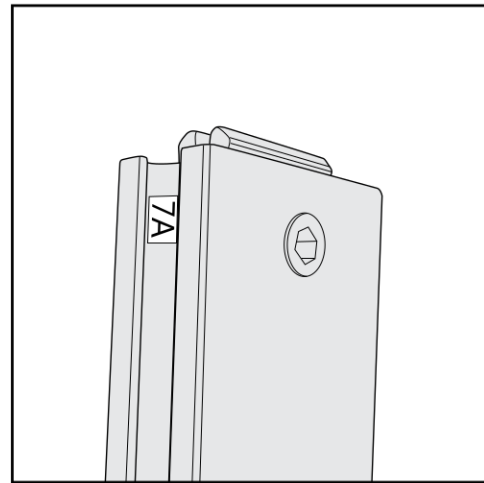

Part Identification - Numbering

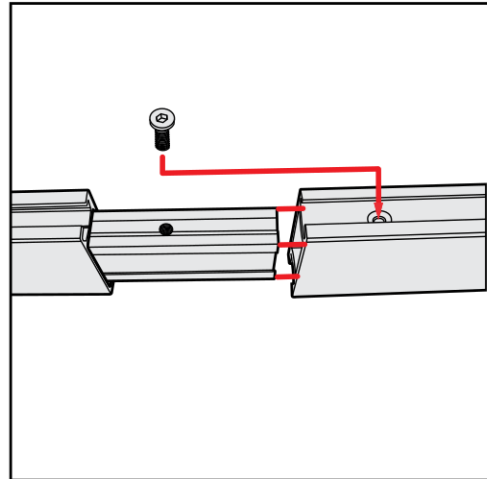

Spline Connection

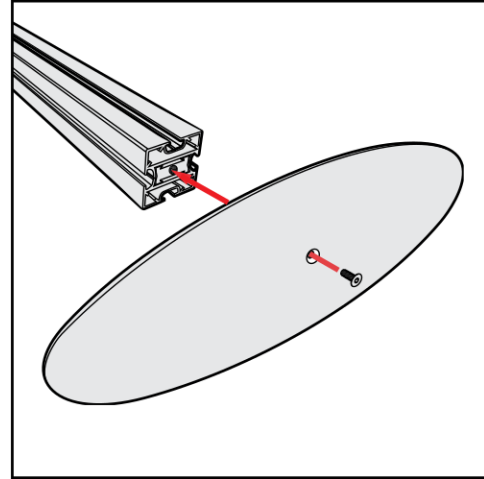

Base Plate & Extrusion Connection

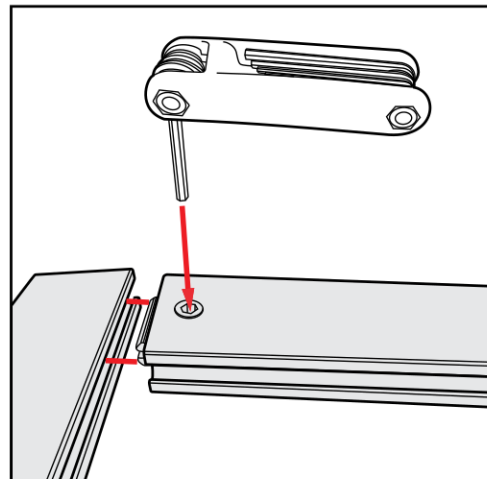

Extrusion & Lock Connection

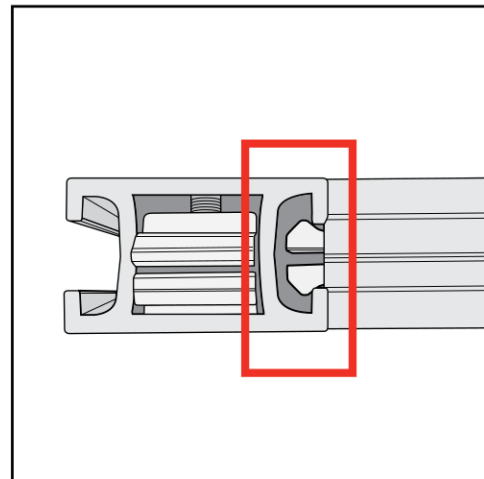

Engaged Lock



**WARNING**



DO NOT USE POWER TOOLS



LADDERS OR LIFTS  
MAY BE REQUIRED



ALL CONNECTIONS MUST  
BE TIGHTLY SECURED

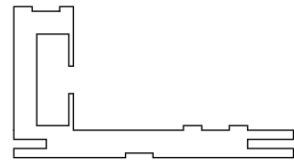

CEI110 Profile

## Corner Bracket Assembly

- 1) Slide TWO-PIECE TS RV 2 L-bracket into Interior Center Slot of extrusion so that two set screws are inside groove. Tighten two set screws to secure.
- 2) Slide one A1 L-Bracket into outer interior grooves of upper and lower horizontals. Tighten set screws to secure.
- 3) Slide vertical extrusion over exposed ends of brackets in lower horizontal. Tighten set screws to secure.
- 4) Slide exposed ends of installed brackets of upper horizontal into open ends of verticals. Tighten set screws to secure.

## Disassembly

- 1) Loosen set screws on brackets and slide extrusions off of brackets.

### Corner Connection

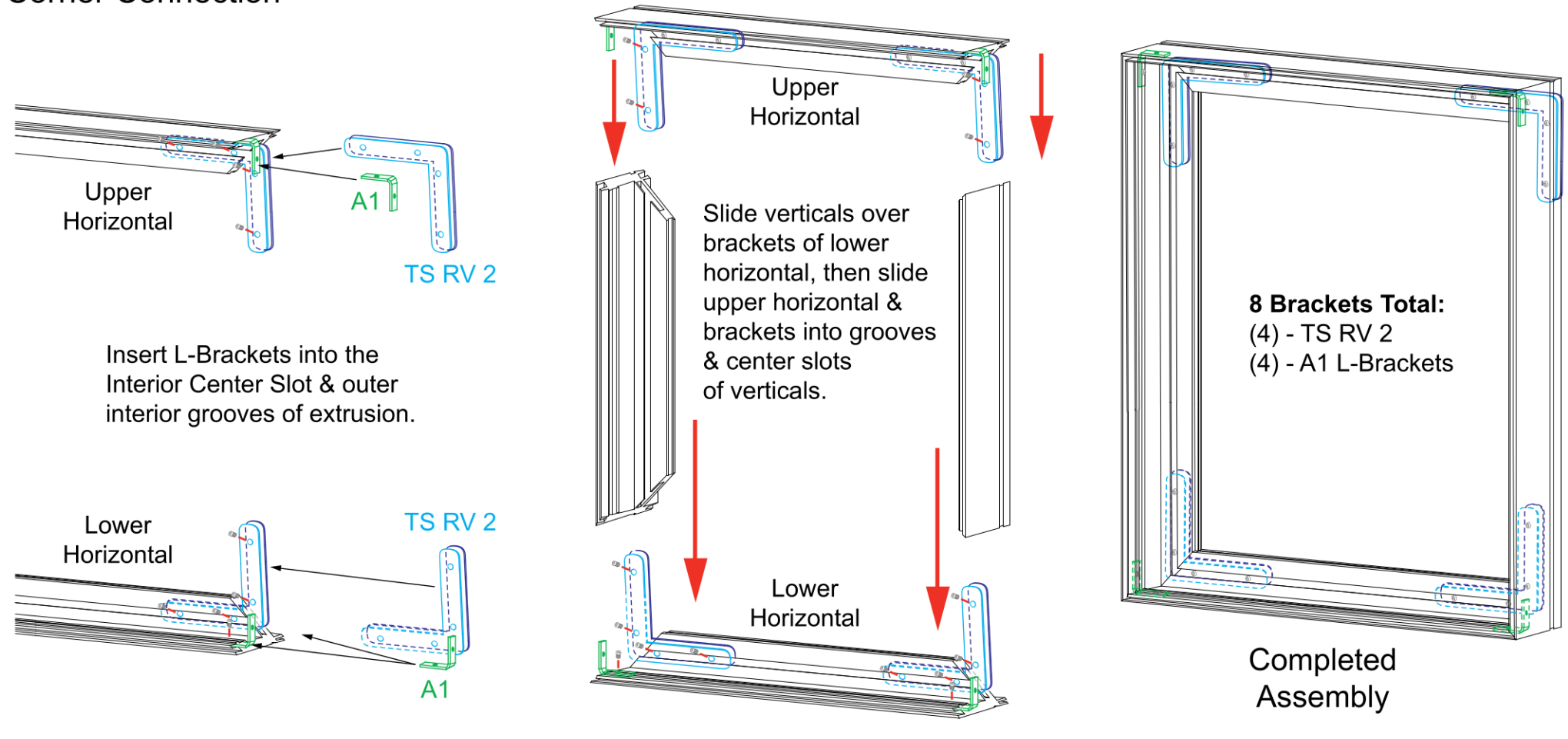

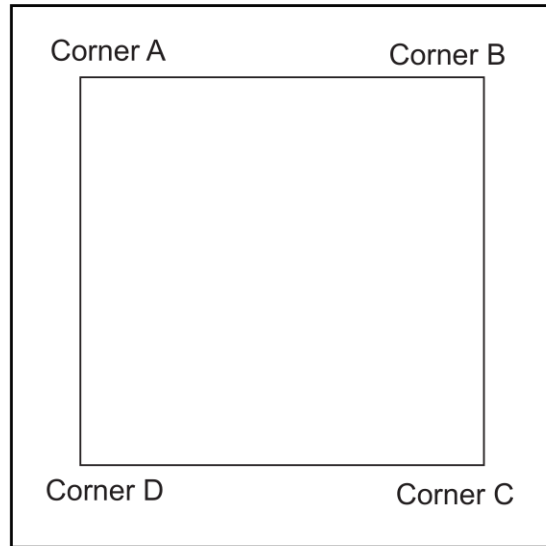

It is important to first insert graphic into each alternate corner then to the sides of the frame. If this is not done, graphic will not fit into the frame correctly.

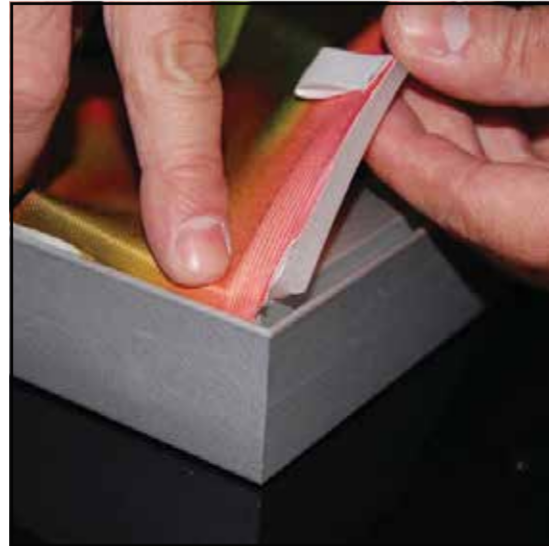

**Step 1**  
Insert corner A. Turn edge of graphic so silicon welt is perpendicular to face of graphic. Insert narrow side of welt with fabric to outside into the channel. Repeat for other side of this corner.



**Step 2**  
Repeat Step 1 for opposite corner C, then insert corner B, followed by corner D, to complete the installation of the corners.



**Step 3**  
Once all corners are inserted, press one silicon edge into channel from corners and work toward the center. Make sure welt is fully inserted into channel. Continue until all sides are done. Smooth out edges of graphic.

### Graphic Removal

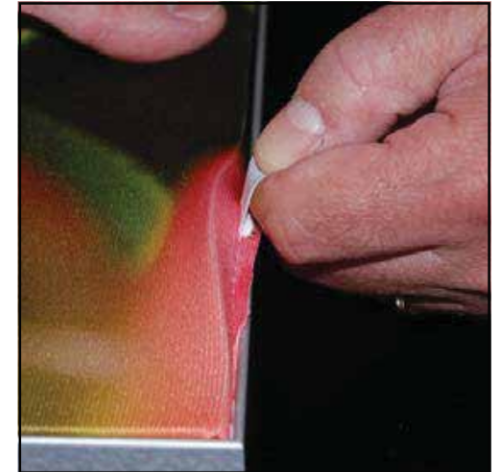

To remove the graphic from the frame, locate the fabric pull tab. Gently pull up on the tab to remove the fabric.

### Top View of Each Level

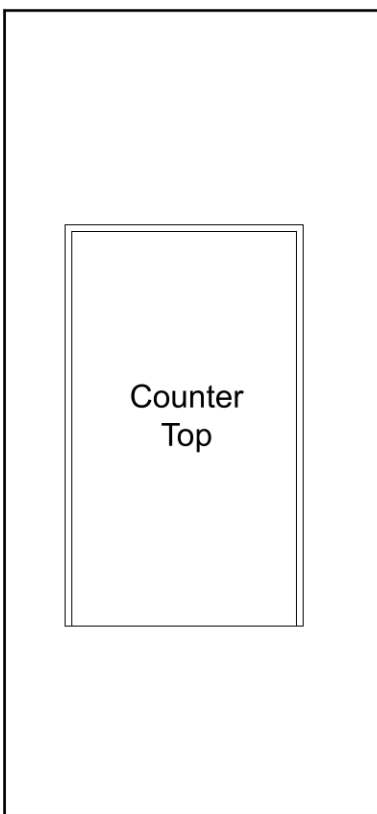

Level 1 (Bottom Level)

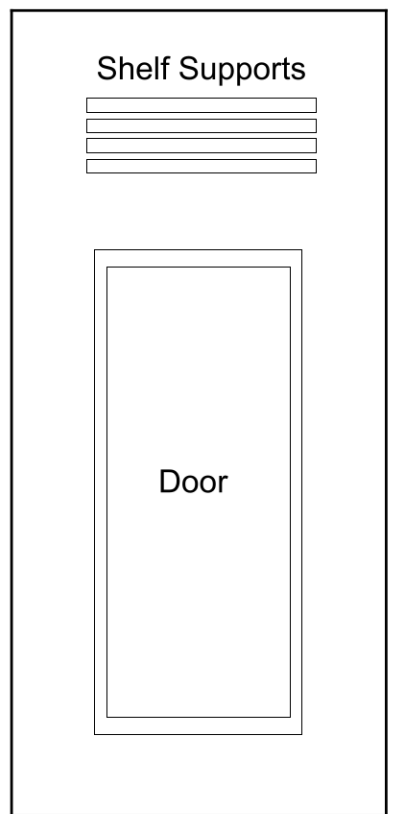

Level 2

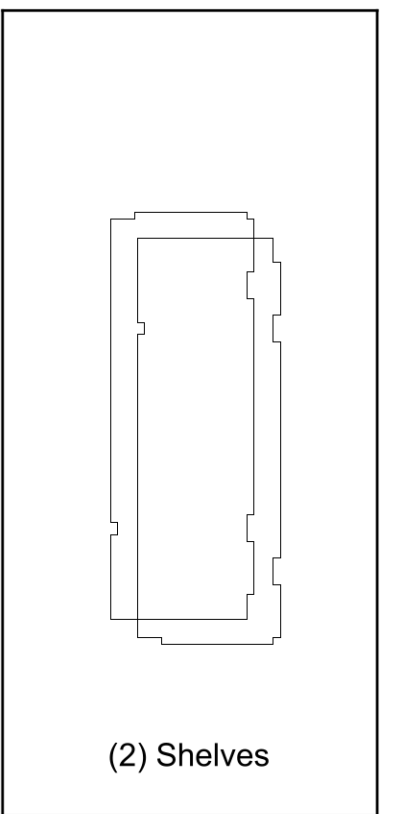

Level 3

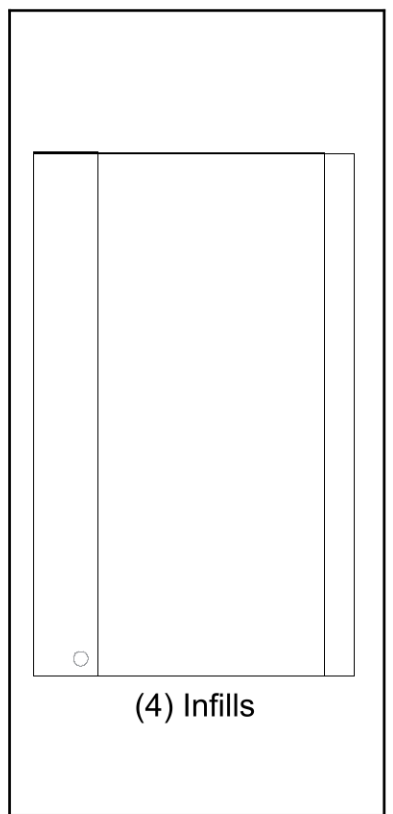

Level 4

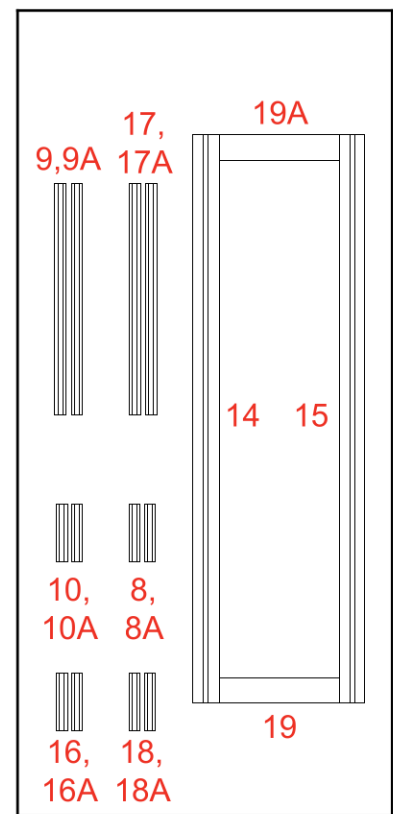

Level 5

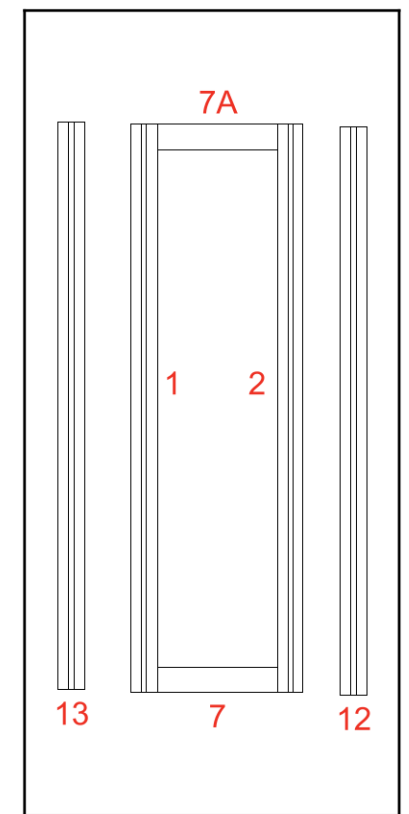

Level 6



### Top View of Each Level

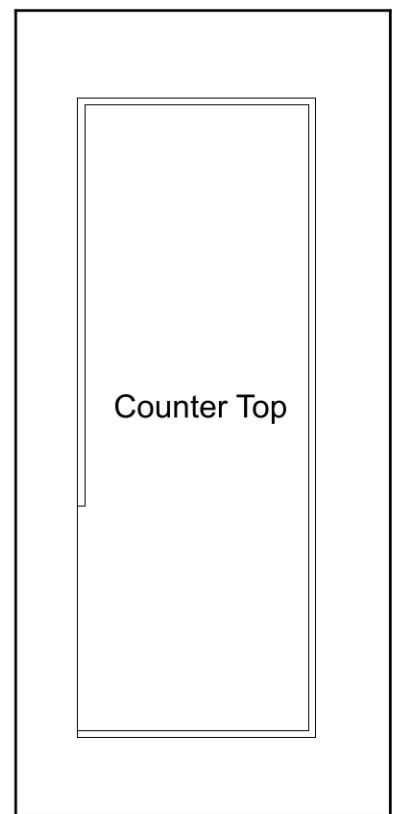

Level 1 (Bottom Level)

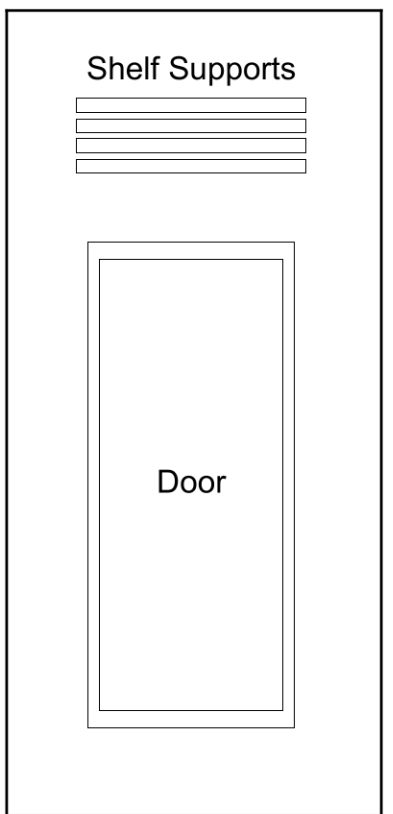

Level 2

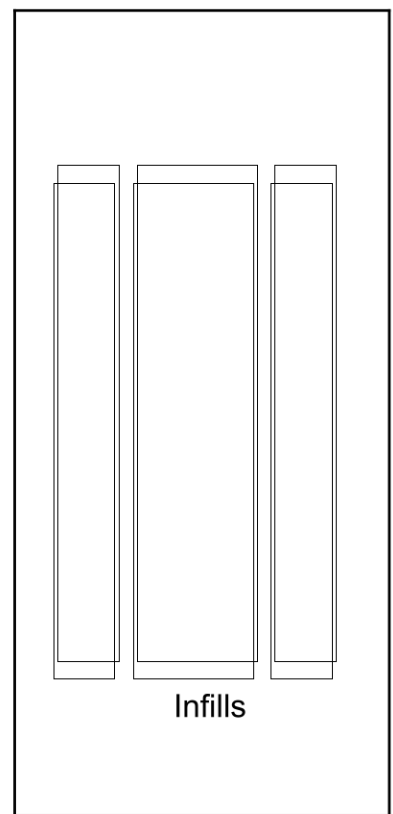

Level 3

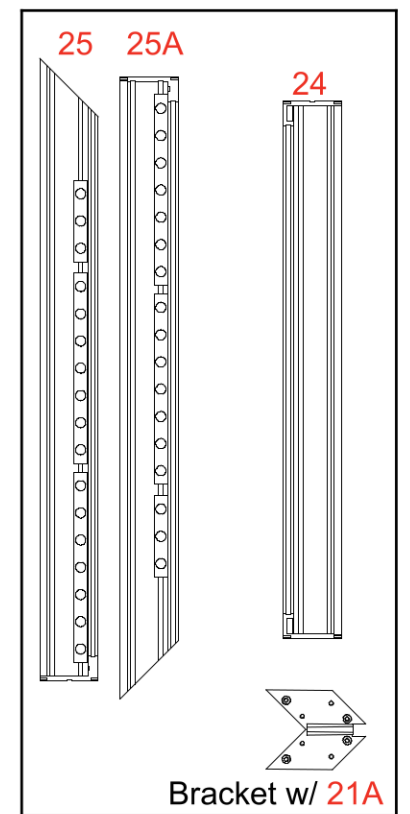

Level 4

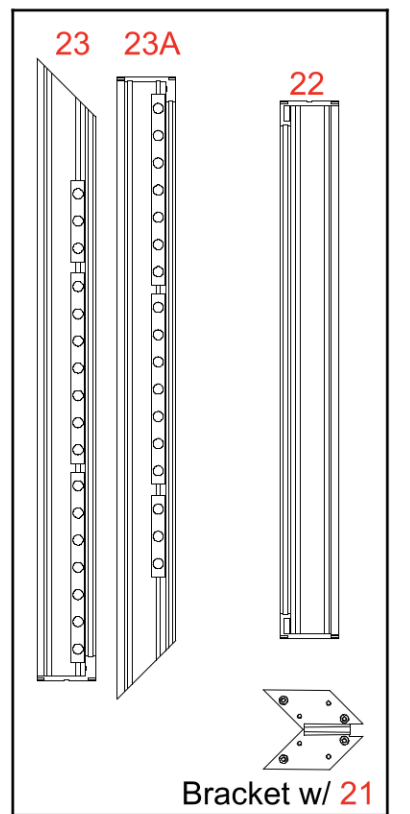

Level 5

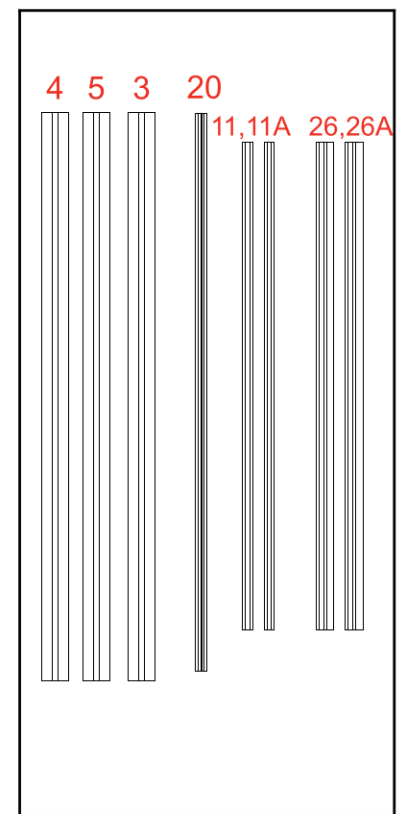

Level 6

Item	Qty.	Description
1	1	39.5" S44 Vertical Extrusion
2	1	39.5" S44 Vertical Extrusion
3	1	39.5" S44 Vertical Extrusion
4	1	39.5" S44 Vertical Extrusion
5	1	39.5" S44 Vertical Extrusion
7,7A	1,1	8.341" Z45 Horizontal Extrusion
8,8A	1,1	4" Z45 Horizontal Extrusion
9,9A	1,1	16.067" Z45 Horizontal Extrusion
10,10A	1,1	4" Z45 Horizontal Extrusion
12	1	39.5" S44 Vertical Extrusion
13	1	39.5" S44 Vertical Extrusion
14	1	39.5" S44 Vertical Extrusion
15	1	39.5" S44 Vertical Extrusion
16,16A	1,1	4" Z45 Horizontal Extrusion
17,17A	1,1	16.067" Z45 Horizontal Extrusion
18,18A	1,1	4" Z45 Horizontal Extrusion
19,19A	1,1	8.341" Z45 Horizontal Extrusion

- Steps:
- 1) Assemble lower horizontals [7,8,9,10] between verticals [1,2,3,4,5].
  - 2) Slide **Infills** between verticals as shown.
  - 3) Attach upper horizontals [7A,8A,9A,10A], securing **infills**.
  - 4) Connect lower horizontals [16,17,18,19] between verticals [4,12,13,14,15].
  - 5) Slide **Infills** between verticals.
  - 6) Secure **Infills** with upper horizontals [16A,17A,18A,19A].
  - 7) Connect doors to vertical [3] and [13]. See **Door Connection** detail.

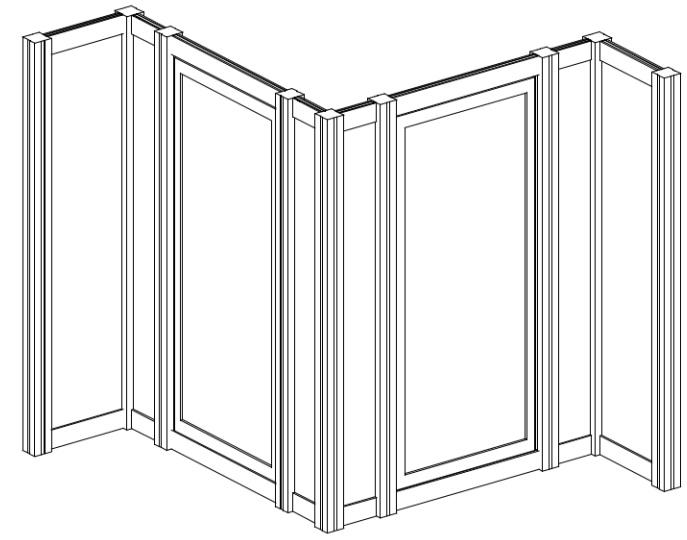

When assembled

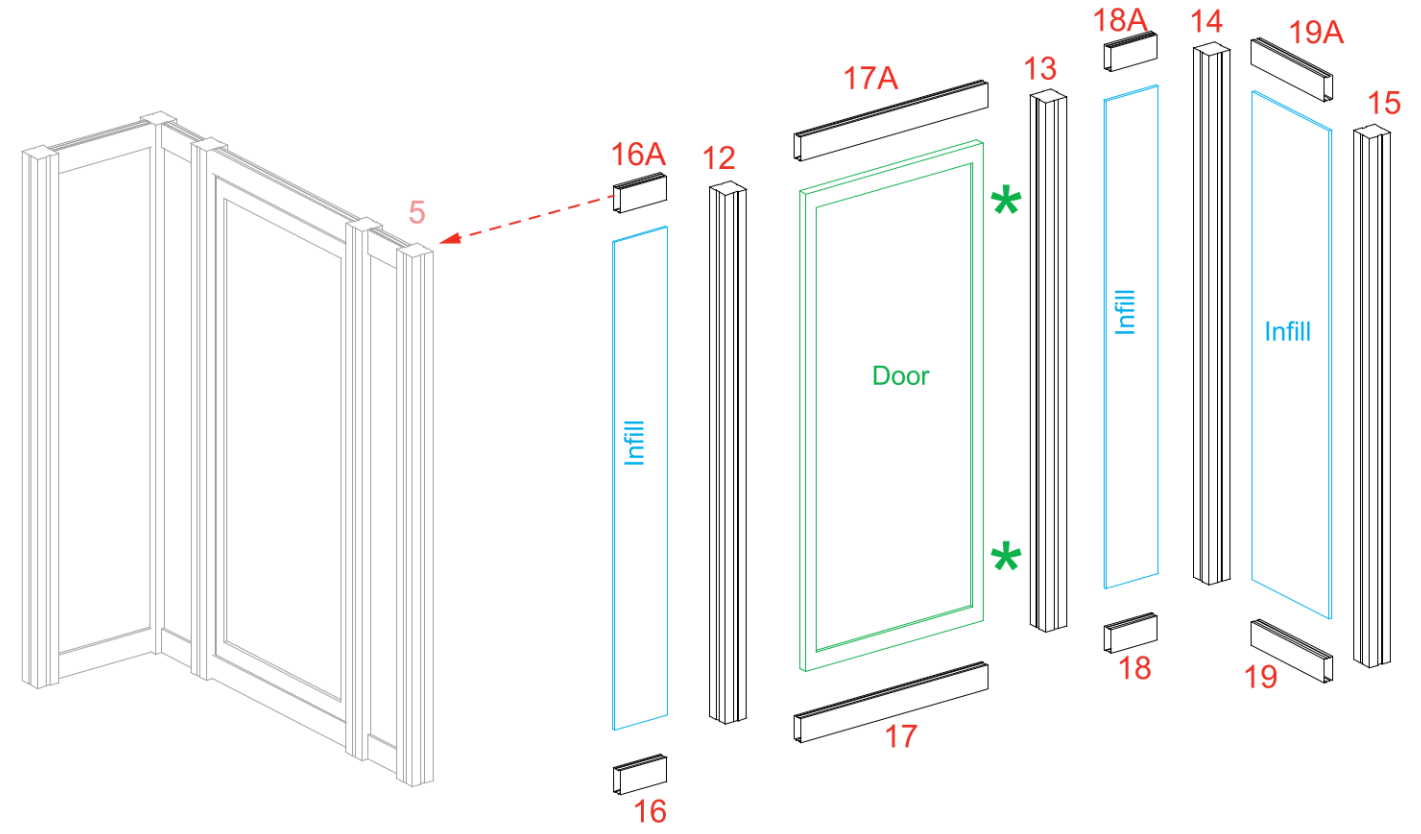
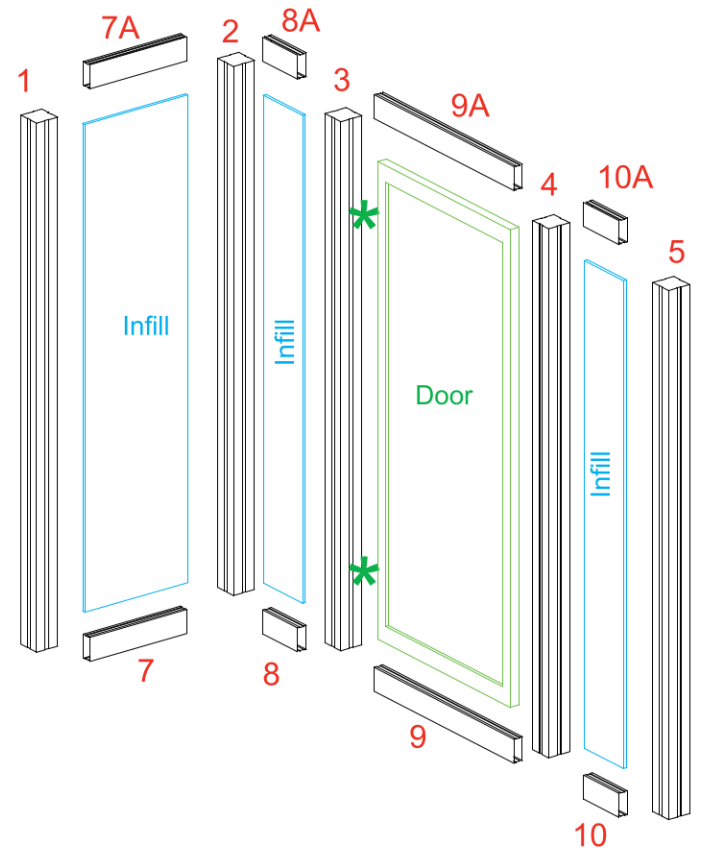
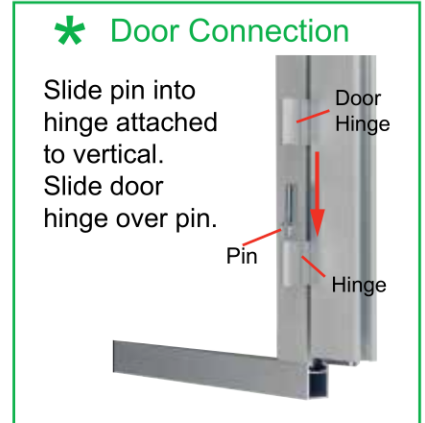

Item	Qty.	Description
11,11A	1,1	35.853" h Z33 Vertical Extrusion
20	1	38.752" TSP2 Vertical Extrusion
21,21A	1,1	3.193" Z31 Horizontal Extrusion
22	1	39.5" CEI110 Vertical Extrusion
23,23A	1,1	45.75" CEI110 Horizontal Extrusion
24	1	39.5" CEI110 Vertical Extrusion
25,25A	1,1	45.75" CEI110 Horizontal Extrusion
26,26A	1,1	35.853" h GS300 Vertical Extrusion

- Steps:
- 1) Connect vertical [22] between horizontals [23,23A], & vertical [24] between horizontals [25,25A]. Refer to the CEI110 Frame Assembly general info page.
  - 2) Attach assembled frames to verticals [1] & [15], as shown. See **Frame to Assembly Attachment** detail.
  - 3) Slide 2-part Infills into back of both assembled frames & secure with verticals [11,26] & [11A,26A].
  - 4) Attach horizontals [21,21A] & two brackets to vertical [20], then attach brackets to CEI110 corners [23/25] & [23A/25A], inserting Infill. See **Z45 & Bracket Connection** detail.

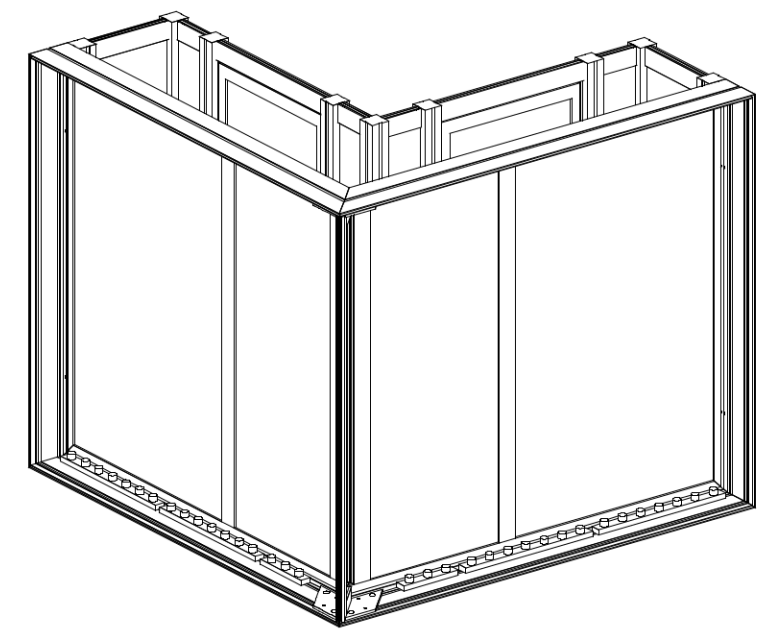
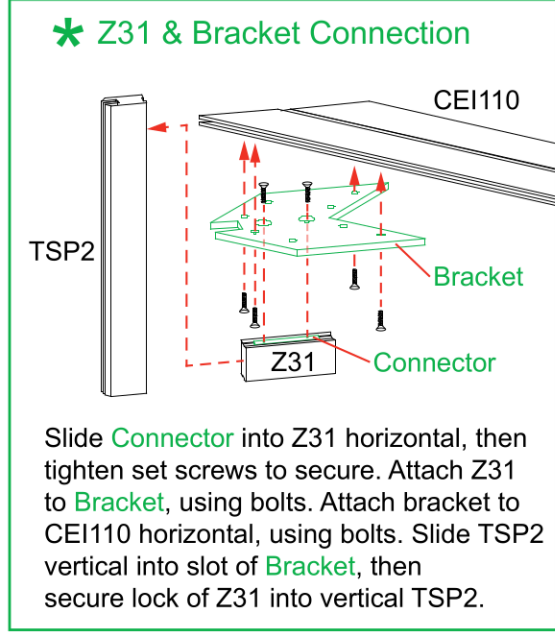
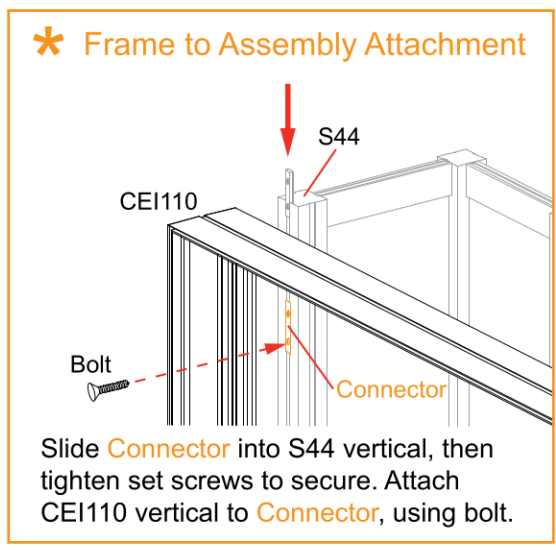

When assembled

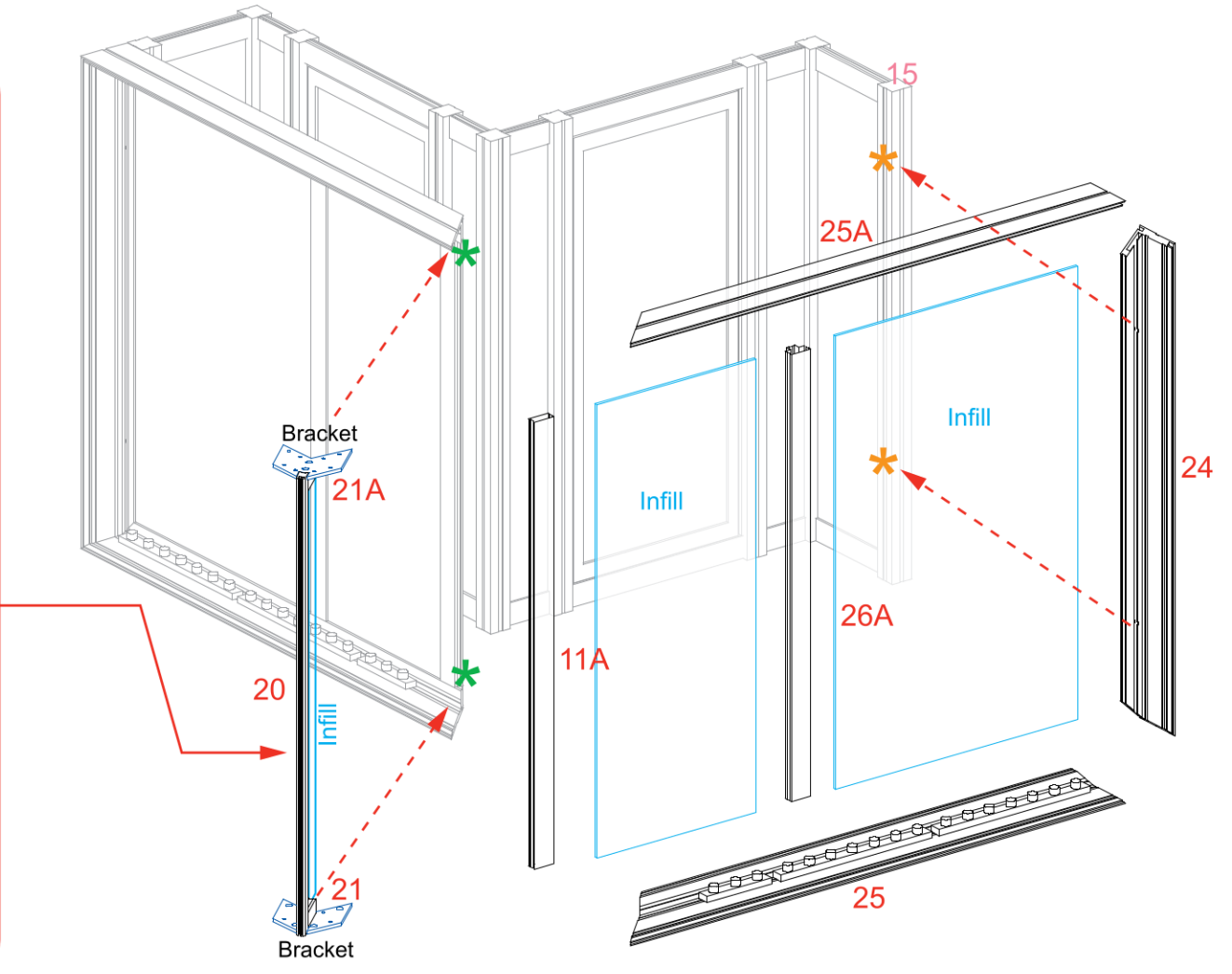
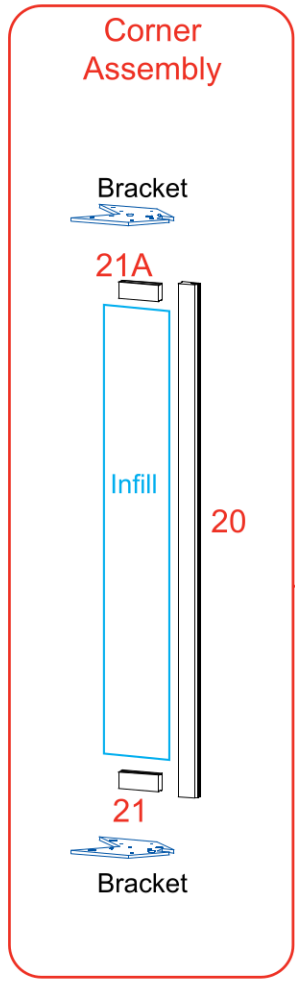
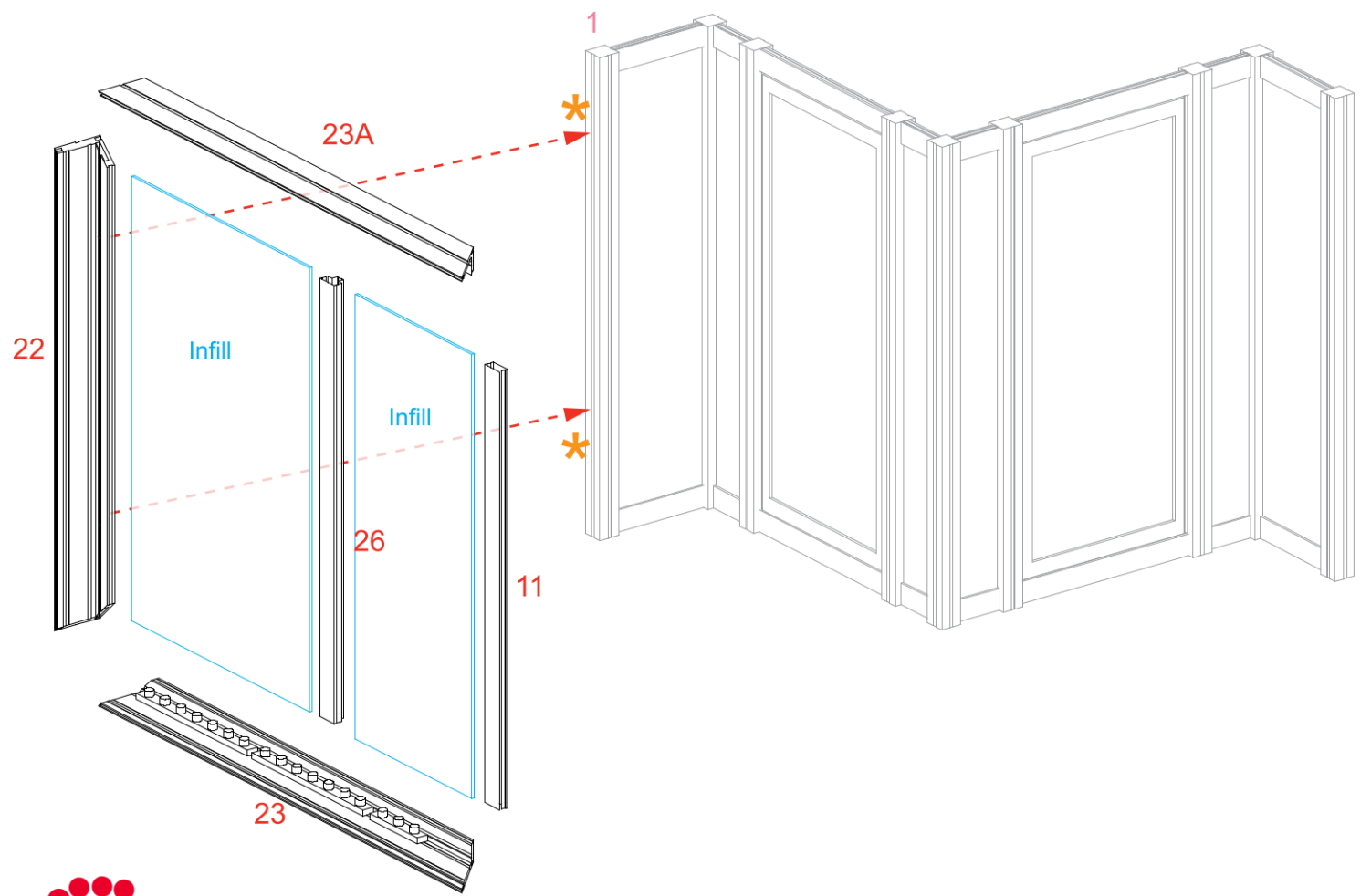



- Steps:
- 1) Connect lighting power cords and attach transformers. See [Light to Light Connection](#) and [Light to Transformer Connection](#) details.
  - 2) Place shelves onto pins. See [Shelf Pin](#) detail.
  - 3) Place counter top on top of assembled counter base. See [Counter Top Attachment](#) detail.
  - 4) Install SEG graphics to front of assembled frames. See [SEG Graphic Installation](#) detail.

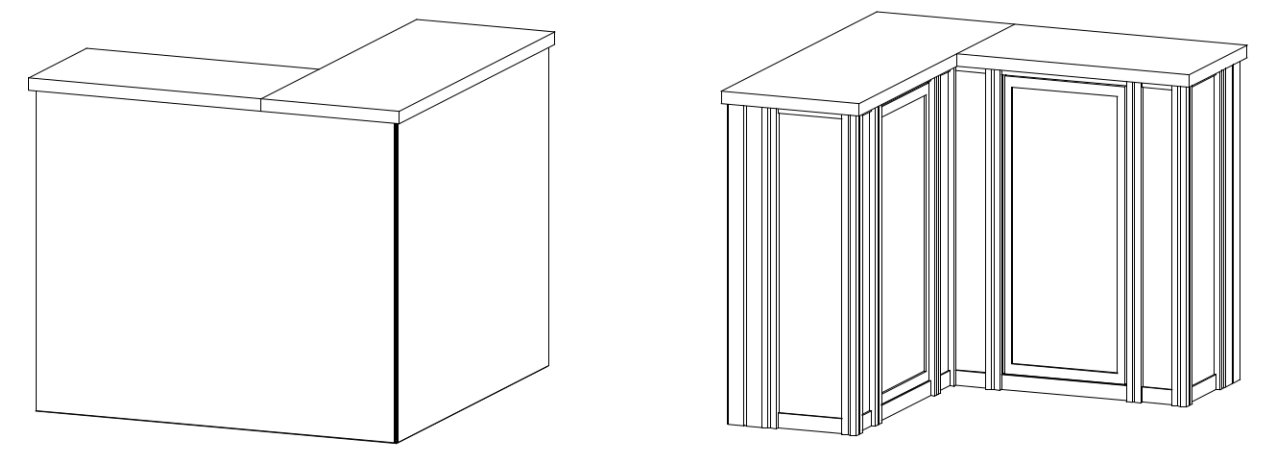

Completed Assembly

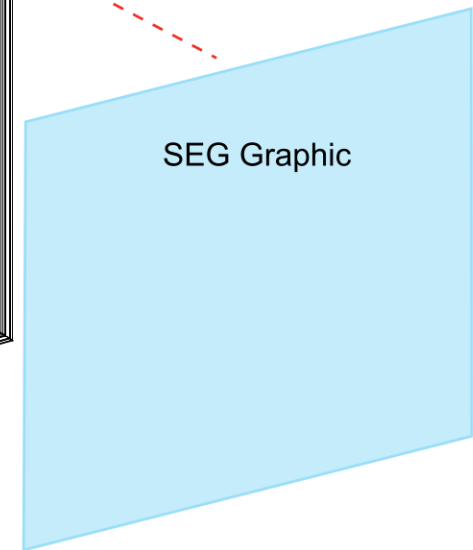
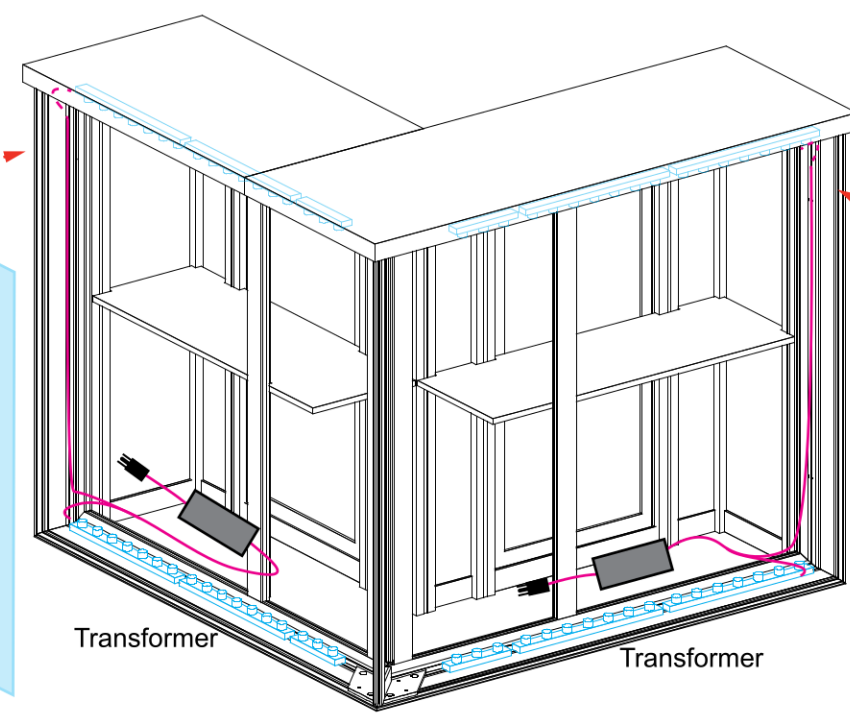
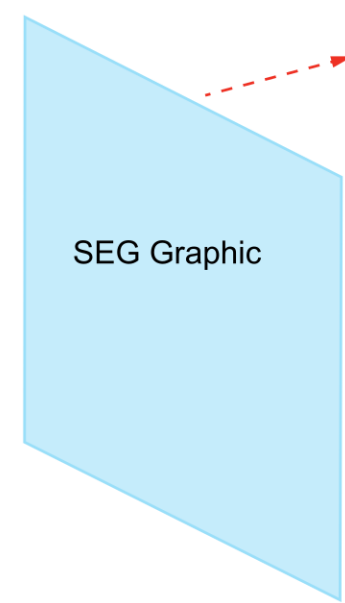
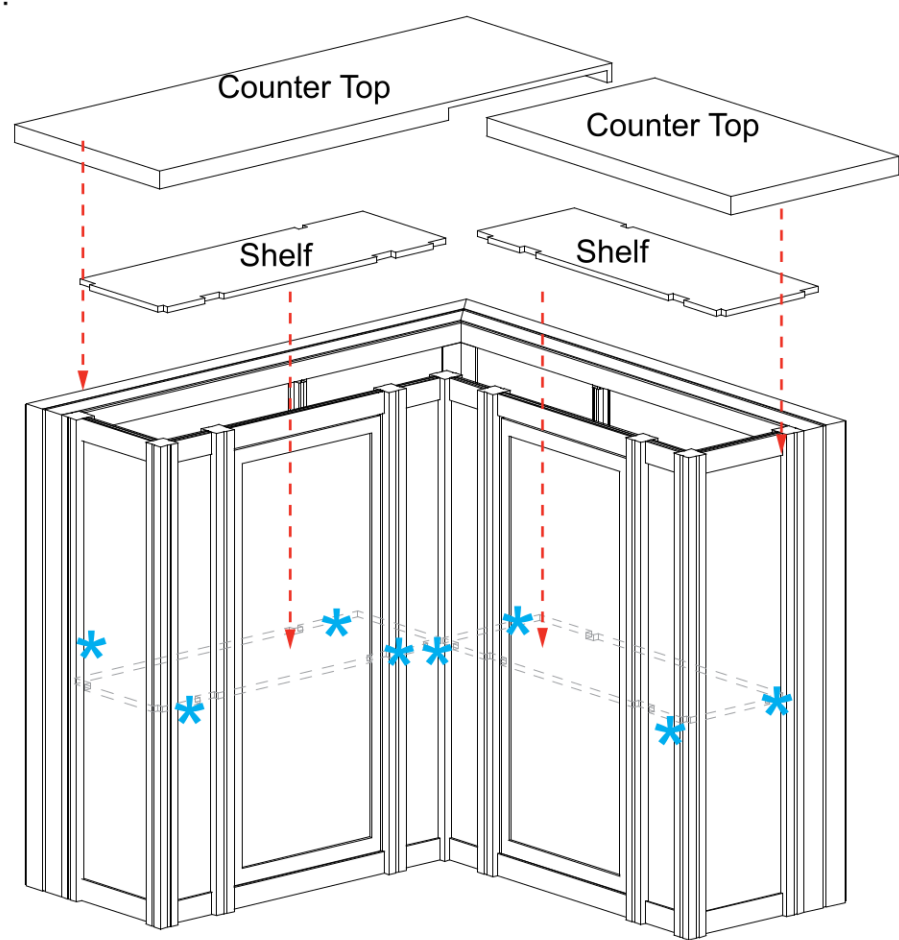
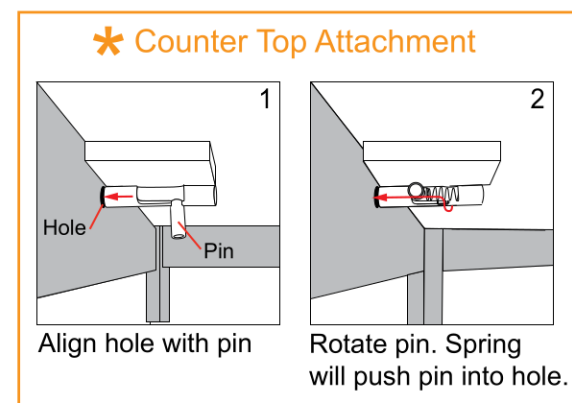
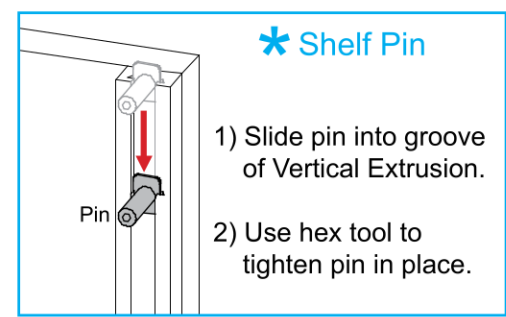
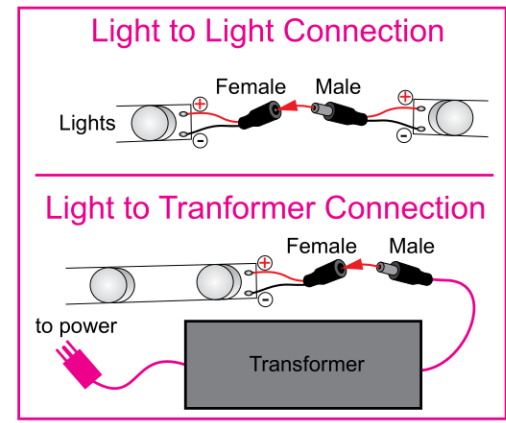

**SEG Graphic Installation**

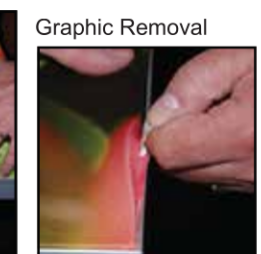
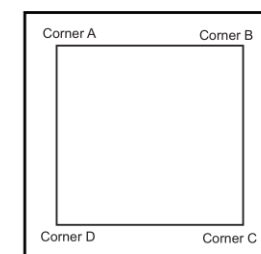

It is important to first insert graphic into each alternate corner then to the sides of the frame. If this is not done, graphic will not fit into the frame correctly.

Step 1  
Insert corner A. Turn edge of graphic so silicon welt is perpendicular to face of graphic. Insert narrow side of welt with fabric to outside into the channel. Repeat for other side of this corner.

Step 2  
Repeat Step 1 for opposite corner C, then insert corner D, to complete the installation of the corners.

Step 3  
Once all corners are inserted, press one silicon edge into channel from corners and work toward the center. Make sure welt is fully inserted into channel. Continue until all sides are done. Smooth out edges of graphic.

Graphic Removal  
To remove the graphic from the frame, locate the fabric pull tab. Gently pull up on the tab to remove the fabric.